



FEATURES

- 80W with 8.6CFM forced air- cooling, 60W convection cooling
- 180 x 52 x 39mm slim size with ATX output
- PG/PF Signal
- +5V Stand by & Remote On/Off
- MTBF>130,000 hr. MIL-217F.

1. Description

MPI-706H-A is a compact ultra-slim size 180 x 52 x 39mm built in AC inlet, ATX output power supply for embedded system application. The device utilizes a thermally efficient U chassis design.

Output Voltage	Mini. Output Current	Rated Output Current	Max output Current ^(Note 1)	Line Regulation	Load Regulation	Ripple & Noise p-p ^(Note 2)	Initial Setting Accuracy ^(Note 3)
+5V	0.2A	5A	8A	1%	2%	50mV	5.08V to 5.13V
+12V	0A	1.5A	4A	1%	4%	120mV	11.4V to 12.6V
-12V	0A	0.5A		1%	5%	120mV	-11.4V to -12.6V
+3.3V	0A	4A	6A	1%	4%	50mV	3.10V to 3.50V
+5Vsb	0A	1A		1%	4%	120mV	4.80V to 5.20V

Total Output Power: maximum 80W with 8.6 CFM forced air-cooling and 60W convection cooling at 50°C ambient temperature.

- Note: 1) The maximum total combined output power on the +3.3V and +5V rails is 40W.
 2) Measured by a 20MHz bandwidth limited oscilloscope and the each output is connected with a 10µF Electrolytic Capacitor and a 0.1µF Ceramic Capacitor.
 3) The +5V output is set between 5.08V to 5.13V by variable resistor and all output at 60% rated load and the other outputs are checked to be within the accuracy range.
 4) While input voltage below 100V (90-99V), an accessory heat sink or the chassis of application (min. 440 cm², aluminum with 1.5mm thickness) is recommend to be placed at the bottom of the power supply itself.

2. Input Specification

Parameter	Conditions/Description	Min.	Nom.	Max.	Units
Input Voltage	Continuous input range.	90	115/230	264	VAC
Input Frequency	AC input.	47		63	Hz
Hold Up Time	Nominal AC Input Voltage (230VAC), rated load.	20			ms
Input Current	Nominal AC Input Voltage (115VAC/230VAC), rated load.			2/1	A
Inrush Current	Nominal AC Input Voltage (115VAC/230VAC), one cycle at 25°C.			30/60	A
Input Protect	Non-user serviceable internally located AC input line fuse.				

3. Output Specification

Parameter	Conditions/Description	Min.	Nom.	Max.	Units
Efficiency	Rated load, 115VAC. Varies with distribution of loads among output.		75		%
Minimum load			See Chart of Description		
Ripple & Noise	Rated load, 20MHz bandwidth		See Chart of Description		
Output Power	Continuous output power.		See Chart of Description		
Line Regulation	Less than ±1% at rated load with ±10% changing in input voltage.		See Chart of Description		
Load Regulation	Measured is done by changing the measured output loading +/-40% from 60% rated load, and keep other output is at 60% rated load.		See Chart of Description		
Turn-on Delay	Time required for initial output voltage stabilization	0.3		4	Sec



4. Interface Signals and Internal Protection

Parameter	Conditions/Description
Power On/Off	The power supply will be turned on when the power On/Off pin is connected to secondary GND.
Power Good Signal	When power is turned on, the power good signal will go high 100ms to 500ms after all output DC voltages are within regulation limits.
Power Fail Signal	The power fail signal will go low at least 1 mS before any of the output voltages fall below the regulation limits.
Over Voltage Protection	For some reason the power supply fails to control itself, the build-in over voltage protection circuit will protect auto-recovery model and to prevent damaging external circuits. The trigger point is about 6.5-8.5V at +5V.
Over Load Protection	Fully protected against output overload and short circuit. Automatic recovery upon of overload condition.

5. Safety Approvals, EMI and EMS Specification

Parameter	Conditions/Description	Min.	Nom.	Max.	Units
Safety Approvals	UL, UL 60950-1				UL approved LVD approved
	CB, IEC 60950-1				
	TUV, EN 60950-1 : 2001				
EMI	EN 55022 / CISPR 22 & FCC Part 15	B			Class
EMS	IEC 61000-4-2, 8KV air discharge and 6KV contact discharge	3			Level
	IEC 61000-4-3, 3V/M	2			
	IEC 61000-4-4, 2KV line & PE	3			
	IEC 61000-4-5, 2KV	3			
	IEC 61000-4-6, 10V	3			
	IEC 61000-4-8, 10A/M	3			
	IEC 61000-4-11				

6. Environment Specification

Parameter	Conditions/Description	Min.	Nom.	Max.	Units
Operating Temperature	Derate linearly above 50°C by 2.5% per °C At 100% load: to a maximum temperature of 70°C At 50% load:	0		+50 +70	°C
Storage Temperature		-40		+70	°C
Relative Humidity	Non-condensing.	5		95	%RH
Altitude	Operating			10K	Feet
	Non-operating			40K	

7. Mechanical Specification

Parameter	Conditions/Description
Dimension	180(L) x 52(W) x 39(H) mm, Tolerance +/- 0.4mm.
Connector	CN1 --- AC input: IEC 60320 / C14 inlet. CN3 --- DC output: Molex 5273-12A or equivalent. CN5 --- DC output: Molex 5045-03A.
Pin Assignment	CN3 Pin
	CN5 Pin

1. +3.3V	4. GND	7. +5V	10. PG/PF
2. +3.3V	5. GND	8. +5V	11. +12V
3. GND	6. GND	9. +5V	12. -12V
1. +5Vsb	2. GND	3. PS on/off	



◆ Mechanical Drawing

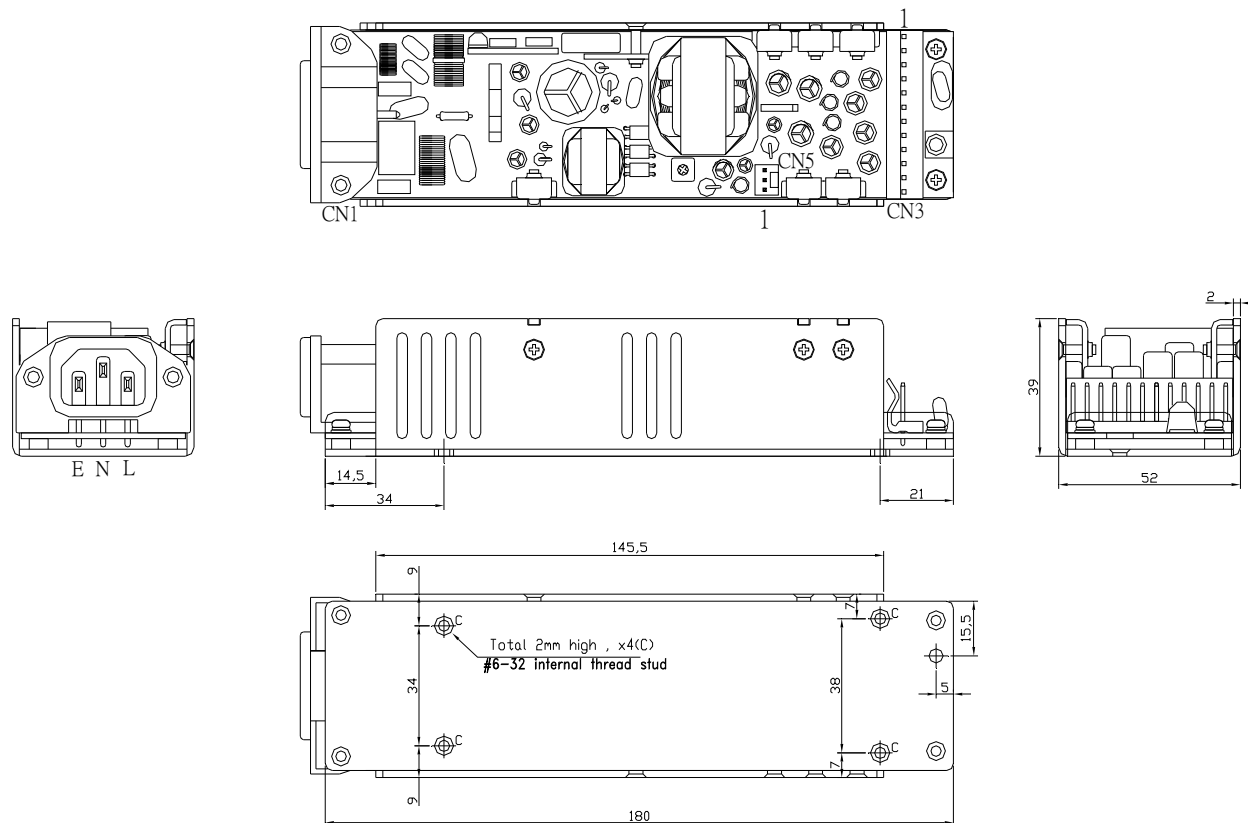

Measuring the screw protrusion first:

